

# Oxford NanoLabs Testimonial



## Oxford NanoLabs

Oxford NanoLabs was originally part of the University of Oxford and was spun out as a new start-up company in June 2005. This organisation mainly develops medical products focusing on the emerging technology of DNA sequencing. They are now housed in state-of-the-art facilities at a University Science Park on the outskirts of Oxford, UK.

## Electronic design work and original design tools at Oxford NanoLabs

A range of low current, low noise, multi-channel circuits much of which is simulated using Spice. Previous experience was with Electronic Workbench Ultiboard PCB layout together with MultiSIM capture and simulation. It was found, however, that these products did not have the ease of use that the user was seeking and in particular the structure of the libraries was not to the customer's liking.

As Oxford NanoLabs started growing, the need increased for the electronic engineering department to produce a number of new designs on quite short lead-times producing prototype equipment ready for demonstration to new investors in the organisation. It became vitally important that any bugs encountered during design work would be analysed and fixed very quickly. Oxford NanoLabs needed to be 100% certain that the toolset supplier could rectify any problems within 24 hours. Unfortunately, they were unable to obtain this level of support with the previous toolset. So, to move forward, the chief engineer Mr White came to the conclusion that Oxford NanoLabs needed a new, more advanced PCB design toolset able to address the specific needs of the new company.

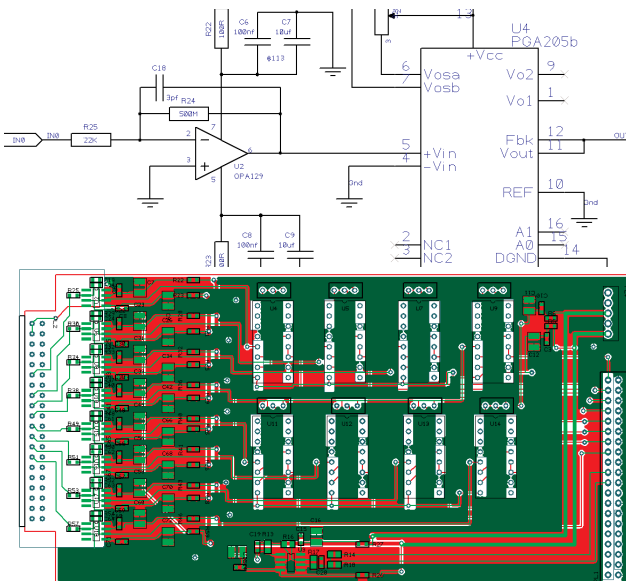

Oxford NanoLabs demands high quality products and service which they receive from Pulsonix



Oxford NanoLabs is based in the new purpose-built facility in Oxford, UK

## Design tools evaluated

A number of potential toolsets were evaluated that combined Spice simulation with PCB Layout. OrCAD and PADS were amongst those considered. They were found to be proficient but were also quite expensive to both purchase and maintain. As the investment in the previous tools did not work out well the customer had to be cautious with any new investment.

## Pulsonix

The customer started to evaluate a demonstration version of Pulsonix and was immediately taken by key elements in the product like general ease of use, the library structure, and the user definable shortcuts. Many designs are mixed metric/imperial so they needed to be able to switch easily during the design process. After an extended product evaluation the customer spoke to some existing Pulsonix users to gauge the quality of the all important support and bug fixing. They were favourably impressed with the responses and the decision to proceed with Pulsonix was taken in April 2006.

## Experiences with Pulsonix since installation

Chief Engineer, Mr Steve White said: "Since installation the product has been in use almost on a daily basis for design capture, simulation or PCB Layout. We have only called the hotline on a handful of occasions and emailed them about 6 times. Each time we got straight through to an engineer who helped us immediately with the query, or the email was answered satisfactorily within an hour or so. This is the level of support and customer care we require and can rely on with Pulsonix."

"As Oxford NanoLabs grows and hires more design engineers we know we can get them up to speed quickly on our new projects as Pulsonix is so fast and easy to use."

"The switch to Pulsonix has worked extremely well for us at Oxford NanoLabs."

**Pulsonix** Oak Lane, Bredon, Tewkesbury, Glos, GL20 7LR, UK  
Tel: +44 (0) 1684 773881 Fax: +44 (0) 1684 773664  
Email: [sales@pulsonix.com](mailto:sales@pulsonix.com) Web: [www.pulsonix.com](http://www.pulsonix.com)